

AS/AL, BL, RS/RL, WS/WL Series

Surge Protective Device (SPD)



Installation, Operation & Maintenance Manual

WARNING – IMPORTANT – PLEASE READ – WARNING
Safety First – Hazardous Voltage & Shock Hazard

- Only qualified licensed electricians should install or service SPDs
- Hazardous voltages exist within SPDs
- SPDs should never be installed or serviced when energized
- Use appropriate safety precautions including Personal Protection Equipment
- Failure to follow these instructions can result in death, serious injury, and/or equipment damage
- This manual shall be read in its entirety prior to installing



Bonding and Grounding Hazard

Verify that the neutral conductor in the service entrance equipment is bonded to ground in accordance with the National Electric Code (NEC®) and all applicable codes.

Verify that the neutral terminal (XO) on the secondary side of distribution transformers are grounded to the system ground in accordance with the NEC® and all applicable codes.

During installation into an electrical system the SPD must not be energized until the electrical system is completely installed, inspected and tested. All conductors must be connected and functional including the neutral (if required). The voltage rating of the SPD and system must be verified before energizing the SPD.

Failure to follow these guidelines can lead to abnormally high voltages at the SPD. This may cause the SPD to fail. The warranty is voided if the SPD is incorrectly installed and/or

if the neutral conductor in the service entrance equipment or downstream of separately derived systems is not bonded to ground in accordance with the NEC®.

Do Not Hi-Pot Test SPDs

Any factory or on-site testing of power distribution equipment that exceeds normal operating voltage such as high-potential insulation testing, or any other tests where the suppression components will be subjected to higher voltage than their rated Maximum Continuous Operating Voltage (MCOV) must be conducted with the SPD disconnected from the power source. For 4-wire systems, the neutral connection at the SPD must also be disconnected prior to performing high-potential testing and then reconnected after test completion.

Failure to disconnect SPD and associated components during elevated voltage testing will damage the SPD and will void the warranty.

Atlantic South Power Critical Systems

PO BOX 1387 · Highlands, North Carolina 28741
(844) 697-6937 · www.atlanticsouthpower.com

UL is a registered trademark of Underwriters Laboratories, NEC® and National Electrical Code are registered trademarks of National Fire Protection Association, C62.41.1-2002, C62.41.2-2002, C62.45-2002, C62.72-2007 are registered trademarks of IEEE.



24-3

INTRODUCTION

Thank you for choosing an Atlantic South Power (ASP) Surge Protective Device (SPD). This is a high quality, high energy surge suppressor designed to protect sensitive equipment from damaging transient overvoltages.

Proper installation is important to maximize performance. Please follow steps outlined herein.

This entire Operation & Maintenance Manual should be read prior to beginning installation. These instructions are not intended to replace national or local codes. Follow all applicable electrical codes to ensure compliance. Installation of this SPD should only be performed by qualified electrical personnel.

ASP SPDs are extensively tested in accordance with industry standards such as ANSI/IEEE C62.41.1, C62.41.2, C62.45, C62.62, C62.72, UL 1449, UL 1283, IEC 61643, etc.

This SPD is a single-port parallel-connected device intended for service entrance, panelboard or downstream installation for IEEE Category C, B or A applications.

Industry Nomenclature Changes

In the late 2000's, there were significant nomenclature changes associated with a revision to UL 1449 and 2008 NEC® Article 285.

- The term 'TVSS' changed to 'SPD'
- Types 1, 2 & 3 SPDs were created, as were Type 1 and Type 2 Component Assemblies (Type 1 CA and Type 2 CA) and Type 4 and Type 5 Components
- UL 1449 clamping voltage performance testing changed from 500A to 3,000A
- UL 1449 added new I nominal testing (I_n), which consists of more rigorous duty-cycle testing CSA 22.2 No. 269 uses similar, but not identical, methodology

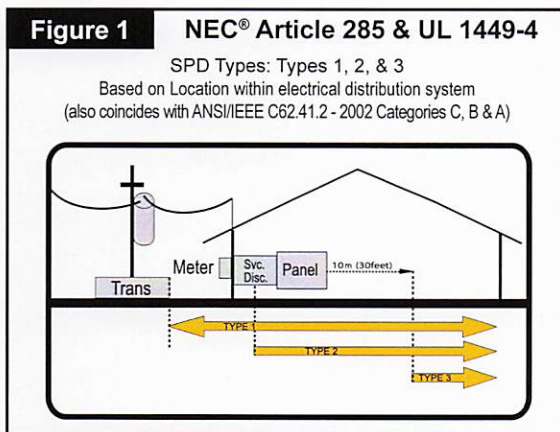

This SPD complies with the latest regulatory actions and is UL Listed as such.

For further information, please review latest editions of NEC® Article 285, UL 1449 or contact APT Tech Support at (800) 237-4567.

GENERAL INFORMATION

Product Family Outline

AS, AL – Single Module in enclosure
BL – Two Modules in enclosure
RL, RS – Single small module for integration by OEM
WS, WL – Single large module for integration by OEM

Type 1 SPD

Type 1 SPDs include internal overcurrent protection and have been evaluated by UL to more stringent requirements. Type 1 SPDs are suitable for installation on the line side or load side of the service disconnect overcurrent device. Type 1 SPDs may be used in Type 2 applications.

Internal Protection

This device features internal overcurrent and overtemperature protection that will disconnect effected surge suppression components at the end of their useful life, but will maintain power to the load – now unprotected. If this situation is undesirable for the application, follow these instructions for servicing or replacing the device.

Service Guidelines

Service of this unit consists of replacing the internal module(s), disconnect switch (if equipped) and/or display assembly.

There are no user-serviceable parts inside the replaceable module. Do not attempt to disassemble the module as it stores charge.

Simplified Explanation of Operation

SPDs sense overvoltage and create a momentary short circuit to redirect harmful surge energy. SPDs reset automatically and wait for the next surge. This is similar to the pressure relief valve on a water heater: pressure goes up, valve opens to relieve pressure and then resets. In an electrical system, an SPD senses overvoltage, shorts temporarily, which equalizes damaging voltages and then resets. SPDs are capable of repeating this function thousands of times.

Parallel Connection

This is a Parallel connected SPD – not series connected. As outlined above, an SPD 'drains off' excessive voltage from an electrical system. Because of parallel connection, installation of the SPD anywhere near the equipment to be protected is satisfactory. This effect is similar to flushing any toilet in a house; pressure in the shower goes down. In an electrical system, a parallel connected SPD will remove excessive voltage off the entire system (assuming reasonable proximity).

Tip: It is very important that wiring leads be configured as short & straight as possible. Avoid long leads. Avoid sharp bends. Route SPD conductors in the same conduit. Leads do not have to be sized for the entire load – this SPD is parallel connected, not series connected. As a generalization, 6 AWG works fine.

Precautionary Statement Regarding SPDs on Ungrounded Systems

Caution – Ungrounded systems are inherently unstable and can produce excessively high line-to-ground voltages during certain fault conditions. During these fault conditions, any electrical equipment including an SPD, may be subjected to voltages which exceed their designed ratings. This information is being provided to the user so that an informed decision can be made before installing any electrical equipment on an ungrounded power system.

Figure 2 TYPICAL PARALLEL CONNECTED SPD ON ELECTRICAL PANEL

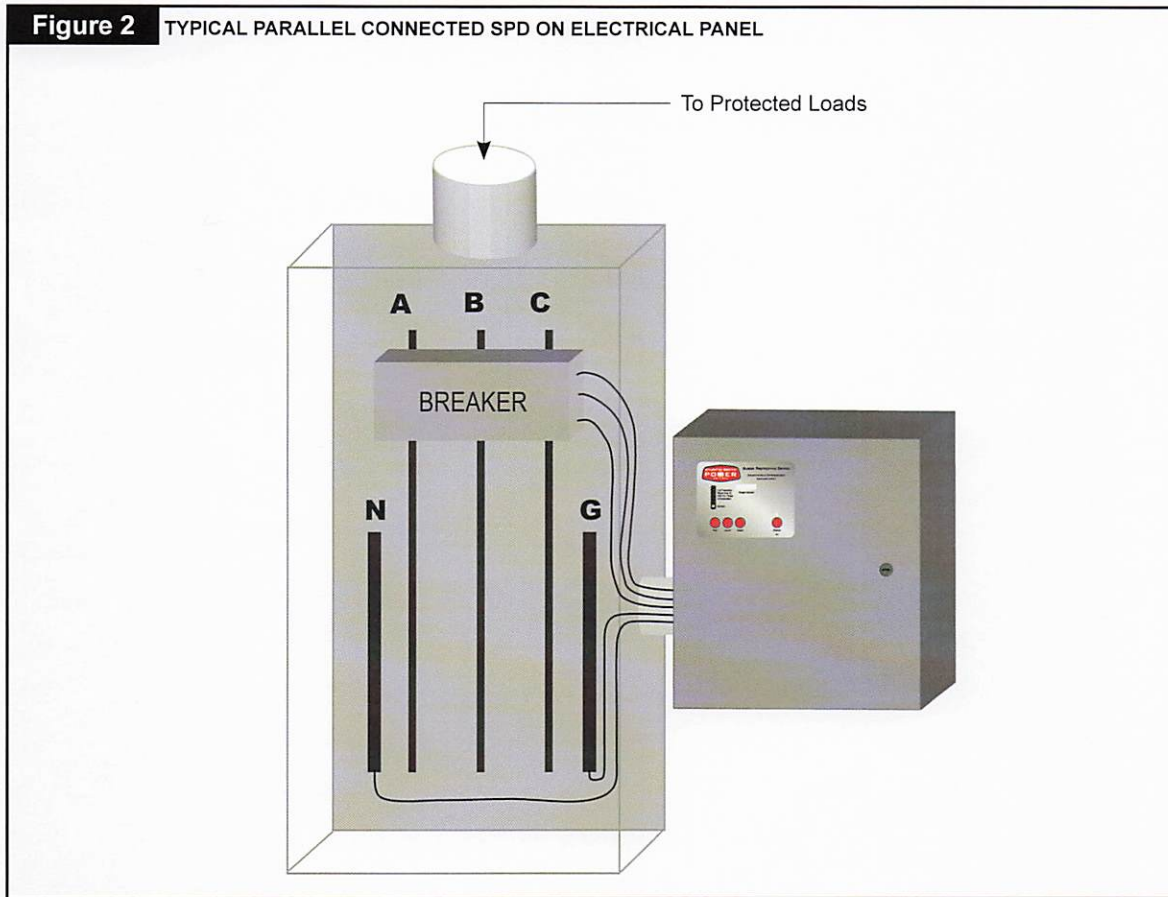

Cascade Surge Protection

For optimum surge protection, cascade or staged surge suppression should be implemented at the service entrance and downstream locations as appropriate. Known or expected surge sources, as well as sensitive loads, should also have localized surge suppression. For interconnected electronic loads (data cabling), SPDs should also be utilized to protect the devices on either end of the interconnecting data cables.

Unpacking & Preliminary Inspection

Inspect the entire shipping container for damage or signs of mishandling. Remove the packing materials and further inspect the unit for any obvious shipping damages.

If any damage was found and is a result of shipping or handling, immediately file a claim with the shipping company and forward a copy to ASP.

Storage Environment

This SPD should be stored in a clean, dry environment. Storage temperature range is -40°C (-40°F) to $+60^{\circ}\text{C}$ ($+140^{\circ}\text{F}$). Avoid exposure to high condensation.

PRE-INSTALLATION & INSTALLATION PLANNING

Operating Environment

The standard unit uses a Type 1/12/3R/4 enclosure. Non-metallic polycarbonate 4X, stainless steel and Type 1 flush-mount or pull box enclosures are available as options. Before installing, ensure that your enclosure type and application are appropriate per NEMA 250 with regard

to moisture, dirt, excessive dust, flammable materials or atmospheres, corrosive vapors, etc. Please consult factory if enclosure needs to be changed.

This SPD is designed in an ambient temperature range of -40°C (-40°F) to $+60^{\circ}\text{C}$ ($+140^{\circ}\text{F}$) with a relative humidity of 0% to 95% (non-condensing). Excessive temperature may inadvertently operate internal thermal overtemperature protectors.

On rare occasions in high temperature climates, SPDs inside clear cover polycarbonate enclosures have experienced internal temperatures exceeding 200°F (94°C). We recommend positioning the unit so that the clear front avoids direct summer sunlight by shading or not facing west.

Line Side versus Load Side Installation

SPDs are tested and qualified as Type 1 SPDs per UL 1449 Fourth Edition and 2008 NEC[®]. This SPD can be installed on the Line Side of the service overcurrent device per 2008 NEC[®] Article 285. Type 1 SPDs may also be installed in Type 2 applications. As a generalization, it is more practical to install as Type 2 on load side of main overcurrent device for maintenance reasons. Such installations would be similar to traditional TVSS installations. (Note: cUL models are Type 2 due to different cUL criteria.)

RS and WS SPD modules are Type 1 and Type 2 component assemblies that have been evaluated by UL for use in Type 1 applications. (RS's and WS's are essentially AS's without enclosures for installation within host electrical equipment.)

There may be circumstances where Line Side installation is desirable. Follow all applicable Code requirements for Line Side installation. We generally recommend that the SPD be installed with a disconnecting mechanism for servicing purposes.

Tip: ASP offers an optional Disconnect Switch that has been UL evaluated as part of the SPD. This includes SCCR and Line Side suitability. If you do not use the APT Disconnect option, select a disconnect switch rated for line side (UL 98) having appropriate SCCR rating including any required overcurrent protection. This may be more time consuming and expensive than anticipated. The optional Disconnect Switch is fully engineered and almost certainly easier, smaller and less expensive.

Audible Noise

SPD background noise is negligible or non-existent, and does not restrict the location of installation.

Mounting, Dimensions, and Weight

The AS & BL series include enclosures and are intended for wall mounting. The RS/RL & WS/WL series are component SPDs intended for installation within other electrical gear already having enclosures. See Table 2. Mechanical drawings are included in back of this manual (page 12).

TABLE 2: DIMENSIONS & WEIGHTS		
AS	H/W/D (in. / mm.)	Weight
Standard (and w/Opt. Disc. Switch & <300kA)	12" x 12" x 7" (305 x 305 x 177)	23 lbs (10.4 kg)
With Opt. Disc. Switch & >300kA	16" x 14" x 6.5" (406 x 356 x 165)	32 lbs (14.5 kg)
4X Non-Metallic (std.) (>300kA w/disc.)	14" x 12" x 7" (356 x 305 x 178)	14 lbs (6.4 kg)
	16" x 14" x 7" (406 x 356 x 178)	21 lbs (9.5 kg)
4X Stainless (>300kA w/disc.)	12" x 12" x 7.5" (305 x 305 x 191)	24 lbs (10.9 kg)
	16" x 14" x 7.5" (406 x 356 x 191)	33 lbs (15 kg)
Pullbox & Flush mount (>300kA w/disc.)	12" x 12" x 6" (305 x 305 x 152)	21 lbs (9.5 kg)
	16" x 14" x 6" (406 x 356 x 152)	29 lbs (13.2 kg)
AL/BL	H/W/D (in. / mm.)	Weight
Standard (includes Disc. Switch)	20" x 20" x 7.5" (508 x 508 x 191)	52 lbs (23.6 kg)
4X Non-Metallic	24" x 24" x 8" (610 x 610 x 203)	52 lbs (23.6 kg)
4X Stainless	20" x 20" x 7.5" (508 x 508 x 191)	53 lbs (24 kg)
Pullbox & Flush mount	20" x 20" x 6" (508 x 508 x 152)	43 lbs (19.5 kg)
RL/RS	H/W/D (in. / mm.)	Weight
Standard	6.5" x 11" x 4.5" (165 x 279 x 114)	5 lbs (2.3 kg)
With Opt. Disc. Switch on alum. backplane	10.75" x 10.88" x 4.5" (273 x 276 x 114)	9 lbs (4.1 kg)
WL/WS	H/W/D (in. / mm.)	Weight
Standard	9" x 11" x 4.5" (229 x 279 x 114)	7 lbs (3.2 kg)
With Opt. Disc. Switch on alum. backplane	14.75" x 12.9" x 5.25" (375 x 328 x 133)	11 lbs (5 kg)

Service Clearance

Service clearance is needed at the front of the unit; 36 inches minimum is the required distance for clearance pursuant to the NEC®.

Lead Lengths & Maximizing SPD Performance

SPDs must be located as close to the circuit as possible to minimize parasitic losses. Surges are high current, high frequency events that cause substantial voltage drops across conductors. This hurts SPD performance. Use the shortest & straightest possible leads. Pre-Plan installations and ensure that nearest breaker positions are used. If new construction, adjust breaker locations as appropriate.

Tip: Voltage drops for normal 120V or 277V lines might be 2-3V per hundred feet. In surge applications, voltage drops might be 100-150V per foot. These voltage drops add to clamping voltage, thus hurting performance. Make every effort to keep leads short and straight.

As distribution gear becomes larger, shorter leads are more difficult to accomplish. When longer leads are unavoidable, gently twist leads together (one to two twists per foot), or tie-wrap leads together.

Tip: surges create magnetic fields per the 'right-hand rule'. When current goes in direction of thumb, magnetic field is in direction of curl of fingers. As surge current goes to SPD, fields are created in one direction. When the SPD sends those currents to neutral and/or ground, current goes in the opposite direction. If 'coming & going' are on the same axis, the magnetic fields can be cancelled, thus avoiding performance decrease. Gentle twists, bundling & tie-wraps accomplish this.

Shortest Leads Possible

- Leads must be as short and straight as possible - See NEC® Art. 285.12
- Pretend wire is \$1000 per foot coming out of your pocket.
- No long leads
- No sharp bends
- No wire nuts
- How short is short enough? As short as you can make it.
- How long is too long? If anyone else can make it shorter.

Overcurrent Protection

SPDs draw very little current under normal conditions and conduct for a brief duration upon encountering a transient surge current. This SPD contains internal overcurrent and overtemperature protection to protect against abnormal voltage conditions.

Supplemental overcurrent protection is not required to protect this SPD. However, connecting conductors require protection in Type 2 applications. Follow applicable codes.

Voltage Rating

Before installing SPD, verify that it has the same voltage rating as the power distribution system. Compare the SPDs nameplate voltage or model number and ensure that SPD configuration matches the intended power source. See Table 1.

The specifier or the user of the device should be familiar with the configuration and arrangement of the power distribution system in which any SPD is to be installed. The system configuration of any power distribution system is based strictly on how the secondary windings of the transformer supplying the service entrance main or load are configured. This includes whether or not the transformer windings are referenced to earth via a grounding conductor. The system configuration is not based on how any specific load or equipment is connected to a particular power distribution system.

480V System Example: SPDs should be installed per the electrical system, not per a load or motor's wiring connection. For example, a 480V three phase motor might appear to be connected as a 480V Delta. In actuality, the serving distribution system might be a 480Y/277V grounded Wye, with or without a neutral pulled to the motor or MCC. The system is still a 480Y/277V Wye, even though the load is connected as a Delta. A grounded Wye has a defined reference to ground (i.e., neutral is bonded to ground). Some Delta systems are ungrounded, which have no reference to ground and are known to become unstable in certain situations. Such instability can cause line to ground voltage fluctuations that may prematurely fail SPDs. For this reason, the NEC® Article 285 has placed SPD restrictions on ungrounded systems. As generalizations, SPDs for ungrounded systems can be installed on grounded systems with a clamping performance penalty. However, SPDs for grounded systems installed on ungrounded systems are almost certainly destined for premature failure. Call ASP Tech Support at (844) 697-6937 for further information.

Circuit Breaker and Disconnect Switch

SPDs are tested and qualified as a Type 1 SPD per UL 1449 Fourth Edition and 2008 NEC®. This SPD can be installed on the line side of the service overcurrent device per 2008 NEC® Article 285. As a generalization, it is more practical to install on load side of main overcurrent device for maintenance reasons.

When connected on load side of main disconnect, we suggest connecting via a 60A circuit breaker. The circuit breaker is the intended disconnect switch and provides short circuit protection to the connecting conductors. These SPDs have internal overload protection elements within the product. A breaker or disconnect is not required for the SPDs overcurrent protection. These SPDs have demonstrated 200kA Short Circuit Current Ratings (SCCRs). 120V & 120/240V models have demonstrated 100kA SCCR. Refer to label on unit.

Terminals

Terminals will accept 14 - 2 AWG conductor and are provided for line (phase), neutral (if used), and equipment safety ground connections. 8 AWG is the minimum recommended wire size because UL testing and evaluation was performed using 8 AWG.

Wire Size and Installation Torque

This is a parallel-connected SPD; it is not series-connected. The size of the SPD wiring is independent of the ampere rating of the protected circuit. Recommended wire is 6 AWG for phase, neutral and ground connections. Torque connections to 18 inch-pounds. Conductor length should be as short as possible.

If other wire sizes are used, we recommend that all conductors be the same gauge. Note that larger conductor might appear to be beneficial. However, large conductor tends to have the same inductance as smaller conductor, thus netting limited improvement in exchange for being more difficult to work with. Terminals accept 14 - 2 AWG conductor with 6 AWG being preferred. Coordinate conductor size and overcurrent protection per applicable codes.

If equipped, Disconnect Switch will accept 6 AWG to 1/0 AWG, with 6 AWG preferred. Torque connections to 18 inch-pounds. Do Not overtorque connections on Disconnect Switch as it Will Break the Disconnect Switch and will not be covered by warranty.

System Grounding

An equipment grounding conductor must be used on all electrical circuits connected to the SPD.

For the best performance, use a single point ground system where the service entrance grounding electrode system is connected to and bonded to all other available electrodes, building steel, metal water pipes, driven rods, etc. (for reference see: IEEE Std 142-2007).

For sensitive electronics and computer systems, we recommend that the ground impedance measurement be as low as possible. When metallic raceway is used as an additional grounding conductor, an insulated grounding conductor should be run inside the raceway and sized per the NEC®. Adequate electrical continuity must be maintained at all raceway connections. Do not use isolating bushings to interrupt a metallic raceway run.

A separate isolated ground for the SPD is NOT recommended. Proper equipment connections to grounding system and ground grid continuity should be verified via inspections and testing on a regular basis as part of a comprehensive electrical maintenance program.

On 4-Wire Power Systems, neutral to ground bonding (Main Bonding Jumper) must be installed per the NEC®. Failure to do so WILL damage SPDs.

Internal Mounting of RS/RL and WS/WL Component SPD
RS/RL's and WS/WL's are essentially AS's without enclosures. RS/RL's and WS/WL's are intended for installation within host electrical equipment having suitable enclosures.

The experienced integrator will appreciate the simplicity of RS/RL/WS/WL. RS/RL/WS/WL's are Type 4 SPDs and have been evaluated by UL for use as Type 1 (or Type 2) SPDs when installed in appropriate enclosures. All UL required safety testing is complete without needing additional safety apparatus. Contact factory for UL file Engineering Considerations. Mount SPD in appropriate enclosure, mount Diagnostic Display in appropriate location and follow appropriate instructions, including short leads. UL evaluation within your completed product should be easy and trouble free. Do not Hi-Pot test with SPD in circuit.

In many instances, a disconnecting means is appropriate for future service. A breaker serves this function, as well as provides overcurrent protection to the connecting conductors. If a breaker or optional Disconnect Switch are not used, consider a disconnect or safety switch having appropriate SCCR rating including any required overcurrent protection. Line side is likely to require a UL 98 switch where load side is likely to require a UL 508 (or UL 98) switch. This may be more time consuming, more expensive and physically larger than anticipated. ASP offers an optional Disconnect Switch that has been UL evaluated as part of the SPD. The optional Disconnect Switch is fully engineered and almost certainly easier, smaller and less expensive. Please contact ASP Technical Support as appropriate.

Mounting Diagnostic Display: Mount the Display in a user-friendly location, with consideration to weather and vandalism. Dimensions are in Figure 4 (page 7). A Display with a 28" connector cable is typically included. Longer lengths are available. The Display is also mountable directly on the RS/RL/WS/WL module (shorter cables required). The standard Display includes mounting thru-holes and is

not weather resistant. Contact factory for weather resistant NEMA 4 rated Display (with mounting studs instead of thru-holes and label material including UL 746C(f1) & UL 94-5VA flame rating).

UL 1283 required language concerning the installation of EMI Filters

a) An insulated grounding conductor that is identical in size and insulation material and thickness to the grounded and ungrounded circuit supply conductors, except that it is green with or without one or more yellow stripes, is to be installed as part of the circuit that supplies the filter. Reference should be made to Table 250-122 of the National Electrical Code regarding the appropriate size of the grounding conductor.

b) The grounding conductor mentioned in item a is to be grounded to earth at the service equipment or other acceptable building earth ground such as the building frame in the case of a high-rise steel-frame structure.

c) Any attachment-plug receptacles in the vicinity of the filter are to be of a grounding type, and the grounding conductors serving these receptacles are to be connected to earth ground at the service equipment or other acceptable building earth ground such as the building frame in the case of a high-rise steel-frame structure.

d) Pressure terminal or pressure splicing connectors and soldering lugs used in the installation of the filter shall be identified as being suitable for the material of the conductors. Conductors of dissimilar metals shall not be intermixed in a terminal or splicing connector where physical contact occurs between dissimilar conductors unless the device is identified for the purpose and conditions of use.

Optional Flush Mount Installation Considerations

The AL, BL and AS are approximately 6" deep. The unit will not mount flush unless there is at least 6" of depth clearance. The AL, BL and AS are not designed to mount flush on a typical 2 x 4 stud wall.

Back Flange Mounting: Mount as close as possible to protected panel. Create a wall opening slightly larger than SPD. See Figure 4. Configure a robust backing plate inside the wall cavity 6 1/16" from the wall face such that the SPD is supported from its back. Note the mounting holes on the back flange. Also note that the SPD weighs 22-52 lbs. Be careful not to drop the SPD into the wall.

Disconnect Switch (Option on AS, AL, RS, RL, WS & WL)

The disconnect switch provides manual disconnection means for phase conductors and the neutral conductor. Ground is not switched.

Special care should be taken while pre-planning installation to ensure that leads are as short as possible. Most SPDs are in 'square' enclosures have backplanes that can be removed and repositioned to reduce leads. See Figure 8. (Models with rectangular enclosures may be repositioned by inverting only.) (Excludes thru-door handle options.)

There is limited working space around the Disconnect Switch. This is a consequence of reducing internal size and lead lengths. Please be patient.

Disconnect switch will accept 6 AWG to 1/0 AWG, with 6 AWG preferred. Torque connections to 18 inch-pounds. OVER-TORQUING connections WILL BREAK the Disconnect Switch and will not be covered by warranty.

The disconnect switch is mounted on DIN-rail. It may be removed by gently pulling out the mounting tab at the bottom of the switch assembly.

ASP is one of few SPD manufacturers that make Disconnect Switches available as a fully UL qualified option. The Disconnect Switch was included during UL certification and testing. The Short Circuit Current Rating posted on the UL label of the SPD includes the Disconnect Switch and supersedes any rating on the individual Disconnect Switch. When used in a Type 1 line-side application, the SPD including its Disconnect Switch has been UL tested and approved. Further evaluation is not required by UL, nor is a separate UL 98 rated switch required.

Module Rotation Feature

Installation lead wire length must be minimized because longer leads hurt performance. Lead length may be reduced by rotating the module inside the enclosure. SPD ships with terminals pointing down. If installation lends itself toward other orientation, the module's aluminum backplane can be unscrewed and reoriented. For example, if leads enter from top, rotate module assembly such that leads are shortest. Be careful with ribbon cable connector and take care to retighten screws & secure ribbon cable. Mounting screws are in four corners. Rectangular enclosures may be rotated up or down only. See Figure 5.

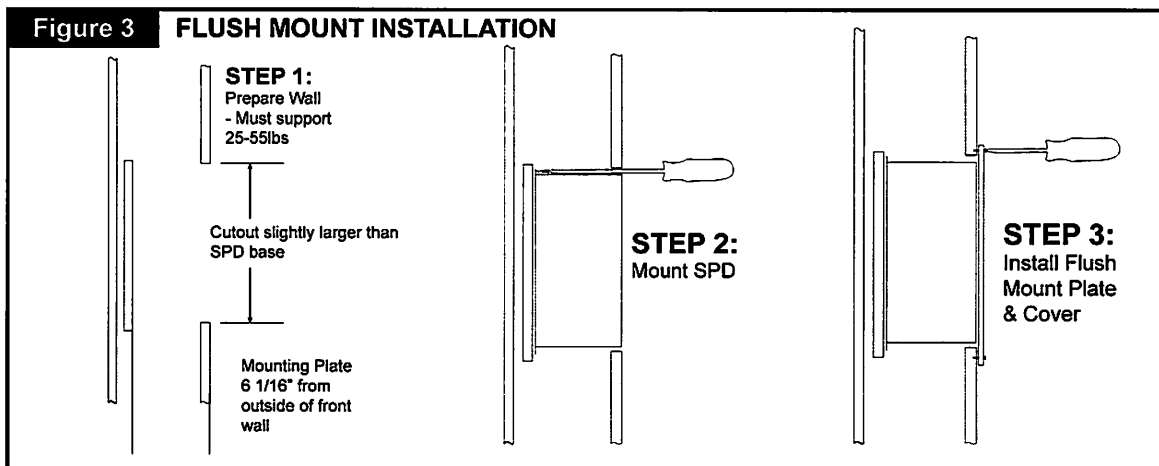

Figure 4 INTERNAL MOUNT DISPLAY DIMENSIONS

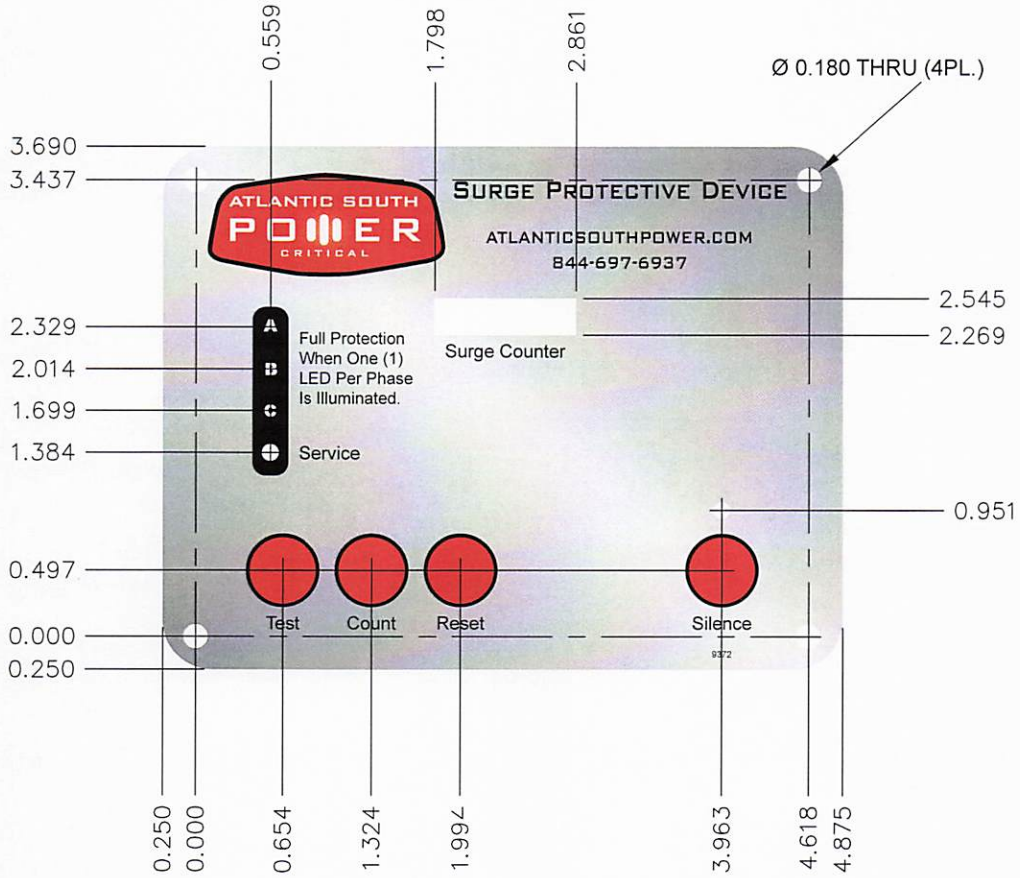
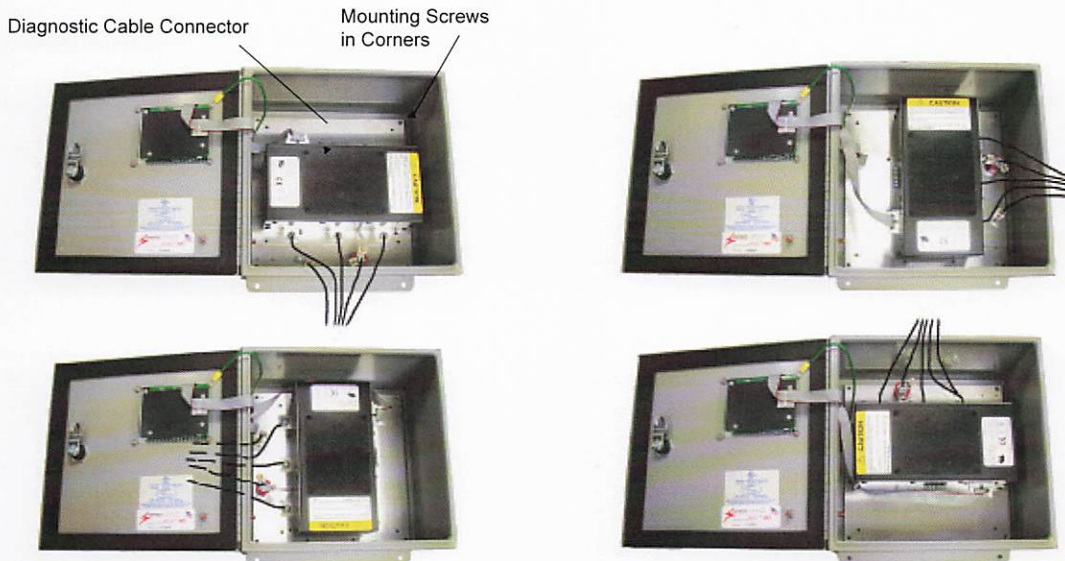

Figure 5 ROTATING MODULE DESIGN ALLOWS FOR SHORTER LEADS



INSTALLATION

Pre-Plan your installation. You will need to accomplish the following:

- Meet all National and Local codes. (NEC® Article 285 addresses SPDs)
- Mount SPD as close to panel or equipment as possible to keep leads short.
- Ensure leads are as short and straight as possible, including neutral and ground. Consider a breaker position that is closest to the SPD and the panel's neutral & ground.
- Suggested breaker & conductor size is 60A-30A with 6 AWG.
- Make sure system is grounded per NEC® and clear of faults before energizing SPD.

Certain options or implementations require extra consideration. See appropriate sections within this manual:

- Line Side Installation (page 4)
- Internal or Integral Mount Installation inside electrical gear (page 7)
- Disconnect Switch Option (page 7)
- Flush Mount Option (page 6)
- Retro-fit where no breaker positions are available (page 11)
- UL/NEMA 3R Drain Holes (page 10)

1. Use a voltmeter to check all voltages to ensure correct SPD.
2. If SPD has Dry Contact, Remote Monitoring or Remote Display, pre-plan their installation.
3. Remove power for panel. Confirm panel is deenergized.
4. Identify connection/breaker location and SPD location.
5. Make sure leads are short. Reducing inches matters. Pretend that connector leads cost you \$1000/foot to make leads short!

Installation Tips: SPD module is mounted on backplane within its enclosure. In many cases, the backplane assembly can be unbolted and rotated in two or four directions to yield shortest leads. See Fig 8. Carefully disconnect ribbon cable(s) and unbolt backplane assembly. Various configurations have limited work space. Please be patient. Installation may be easier if disconnect switch is temporarily removed from DIN-rail, or module/backplane is temporarily removed.

6. Remove an appropriately sized knockout from panel. Create an appropriately sized and located hole in the SPD enclosure.
7. Mount SPD. Connect to equipment using an approved wiring method, including seals appropriate for the enclosure rating. Carefully reinstall backplane or disconnect switch as appropriate.
8. Connect conductors as appropriate – short and straight as possible (Note that Hi-Legs are Phase B).
9. Label or mark conductors as appropriate (neutral: white, ground: green, energized: black, hi-leg: orange).
10. Make sure system is bonded per NEC® and is clear of hazards or faults before energizing (N-G bonding not per NEC® will fail SPDs: #1 cause of SPD failures).
11. Energize and confirm proper operation of indicators and/or options. If Red LED flashes & Audible Alarm cycles, deenergize immediately and call for help.

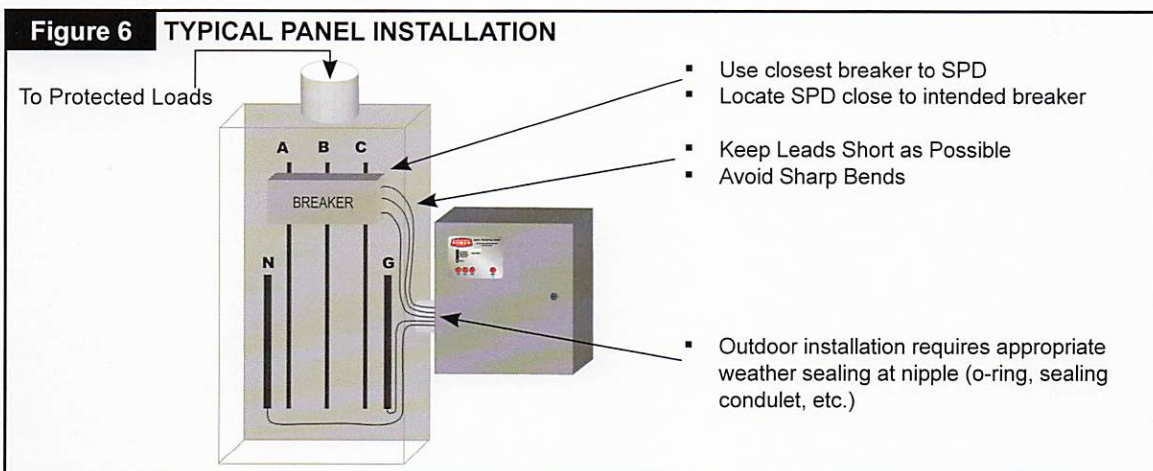
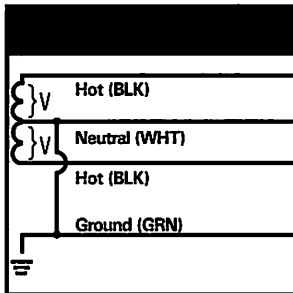
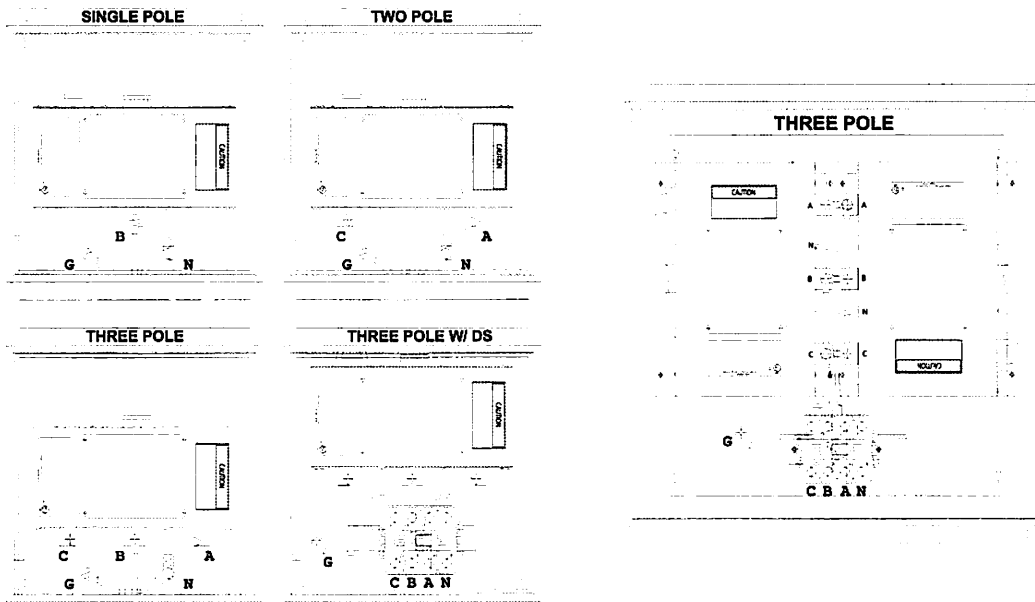
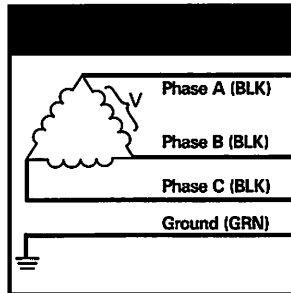

Figure 7 ELECTRICAL DRAWINGS FOR CUSTOMER CONNECTIONS



SPLIT
2 Hots, 1 Neu, 1 Gmd



DELTA & HRG WYE
3 Hots, 1 Gmd

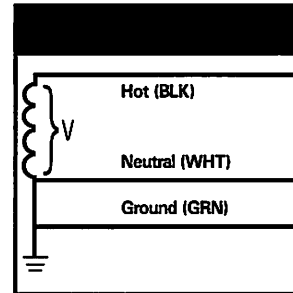

SINGLE POLE
1 Hot, 1 Neu, 1 Gmd

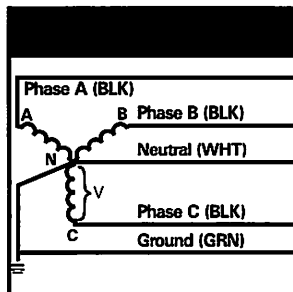

WYE
3 Hots, 1 Neu, 1 Gmd

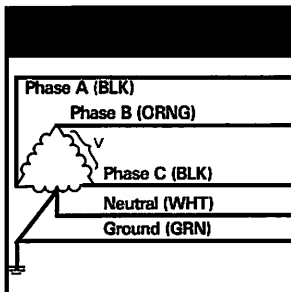

HI-LEG DELTA (B High)
3 Hots, (B HIGH),
1 Neu, 1 Gmd

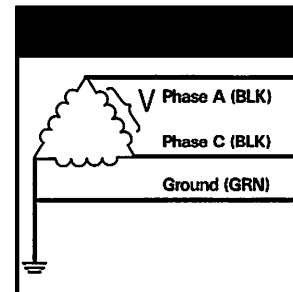

CORNER GROUND DELTA (B grounded)
2 Hots, 1 Gmd

OPERATION

Diagnostic Display Panel

All indicators and controls are located on the diagnostic panel. The diagnostic panel is located on the front of the SPD enclosure or behind the door on certain optional enclosures. Each phase features a Green LED indicator. Green LEDs indicate correct operation.

If an inoperative condition were to occur, the built-in audible alarm will sound and the red Service LED will illuminate. This indicates that the unit needs evaluation by a qualified electrician or technician. Until a qualified person evaluates the unit, press Alarm Silence to silence the alarm. (The LED above Alarm Silence illuminates when the alarm is deactivated. Normal operation occurs with the Alarm Silence LED extinguished.) The red Service LED will remain illuminated even though the Audible Alarm has been silenced. Test tests the red Service LED, the Audible Alarm, and changes the state of Dry Contacts (if equipped).

If LEDs are illuminated in a manner that suggests contradictory information, there may be an internal logic problem and the unit needs replaced. If none of the LEDs are illuminated, the unit may not be installed correctly. For troubleshooting assistance, please contact ASP Technical Support at (844) 697-6937.

Surge Counter Option

The surge counter registers the number of transient overvoltages on all L-N and L-G modes since the counter was last reset. The counter is inductively coupled from each mode of protection. It increments upon significant current change in a short time period (large di/dt).

The surge counter includes Count and Reset buttons on the touchpad display. Pressing Count adds one count. Pressing Reset clears the counter's memory and sets the display to zero.

The counter includes an Eprom memory chip to store the surge count in the event of a power loss. The Eprom requires no maintenance giving it an advantage over replaceable batteries. The surge counter display will be blank if all power is lost to the SPD but will retain the last count shown on the display once power is returned.

NEMA 3R Drain Holes for Standard Steel Enclosure

In order to maintain a UL 3R rating, two 0.25" (6mm) holes must be drilled in opposite corners of the bottom surface of the enclosure. Take care to not damage internal SPD components. Remove any drilling remnants. (Do not perform on other enclosures or ratings.)

Figure 8 NEMA 3R DRAIN HOLES

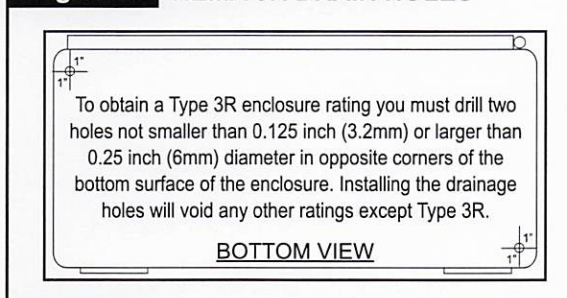
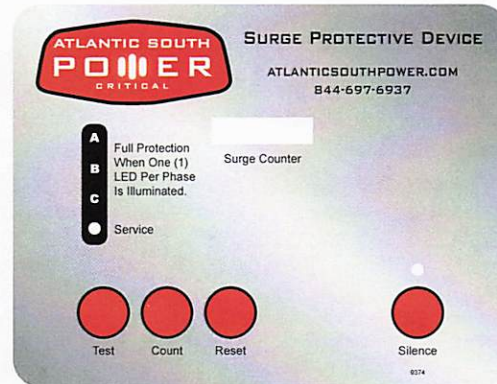

Figure 9 DIAGNOSTIC DISPLAY PANEL



Phase A, B & C: Green LED indicators—one per phase. Green is good. Out indicates problem. Every suppression element in this SPD is monitored. (N-G indicates on Phase A)

Service LED (Red): LED illuminates in the event of problems. This indicator is logic-connected to the Phase LEDs. Should a Phase LED go out the Service LED will illuminate and the Audible Alarm will sound.

Test: Tests red Service LED and Audible Alarm, and changes state of Dry Contacts.

Alarm Silence: Turns Audible Alarm off. (Alarm is deactivated when the Silence LED is illuminated.)

Surge Counter Count: (if equipped) Increments optional surge counter by one. (+1)

Surge Counter Reset: (if equipped) Resets optional surge counter to zero. (0)

Remote Monitor Accessory Option

A Remote Monitor is available for remote annunciation. It requires a standalone 120V power source (wall plug transformer) and uses one set of Form C dry contacts. The Remote Monitor can be configured to monitor several ASP SPDs simultaneously. Installation is detailed in a separate document. Contact factory as appropriate.

Retro-fit Into Existing Panel with No Available Breaker Positions

These can be difficult with limited options. Follow all applicable Codes:

- Consider consolidating loads in a manner that might free breaker positions.
- A ten foot tap rule in NEC® 240.21(B)(1) allows you to tap the bus as long as the tap conductors are rated at least 10% of the ampacity of the panel. This works well if the panel is about 600A or less: Tap the bus, run short 6 AWG leads to the SPD. An SPD with a Disconnect Switch allows for easier SPD servicing in the future. If the panel starts getting large (>800A), then the conductor size increases, which may also become too large to fit into the SPD lugs or too cumbersome to work with. In that case, consider tapping the bus per NEC® 240.21(B)(1). Run appropriate

size conductors to a safety switch fused to 60A. Mount the SPD immediately adjacent to the safety switch. Connect SPD to the load side of the safety switch with 6 AWG. Keep all leads as short as possible.

- Install on Line Side by taking advantage of Type 1 SPD rating. Consider an SPD with a Disconnect Switch.
- In no-win situations, consider asking the Authority Having Jurisdiction (AHJ) for guidance. Some AHJ's appreciate SPD safety benefits on smoke detectors, medical equipment, security equipment, etc. Similarly, some AHJ's appreciate the financial distress of failed microelectronic loads.

Dry Contact Option

Two sets of Form C Dry Contacts are included with the Dry Contact option. Dry Contacts change state during inoperative conditions, including loss of power. Any status change can be monitored elsewhere via Dry Contacts.

A Terminal Block includes two sets of Normally Open (N.O.) and Normally Closed (N.C) contacts. Both sets of contacts operate the same. This is shown in Figure 10. A typical application using a Normally Closed configuration would connect to one set of the N.C. and Common terminals. During an inoperative condition, the SPDs dry contact would change state from normally closed to open. We generally suggest the Normally Closed configuration because it will detect a wiring defect, such as cut wire(s), where N.O. will not.

Please note: Dry Contacts are designed for low voltage or control signals only.

- Maximum switching current is 5A
- Maximum switching voltage is 240V DC or AC.
- Higher energy applications require additional relay implementation outside the SPD.

An optional Remote Monitor accessory is available to provide visual and audible status. The Remote Monitor will consume one of the two sets of Dry Contacts.

MAINTENANCE

SPDs require minimal maintenance. We recommend periodic inspection of diagnostic indicators to ensure proper operation. We also recommend keeping the SPD clean as appropriate.

Troubleshooting & Service

Please contact us for any service related issues. We want to take care of any problems.

Quality SPDs are designed and tested to withstand severe duty. However, there are various electrical anomalies that SPDs cannot protect against. These are generally Sustained Overvoltages also known as Temporary Overvoltages (TOVs). In this context, Sustained Overvoltages may be only a few cycles. Failed SPDs tend to be symptoms, not root causes. A failed SPD should be treated as a 'canary in the coalmine' suggesting further investigation as there may be a larger issue at play. Regardless of cause, SPDs attempt to protect their load until failure.

As noted above, the single largest 'killer' of SPDs is reference to ground issues. If the SPD shows problems on startup, there is reasonable chance of bonding/grounding/

Figure 10 DRY CONTACT OPTION

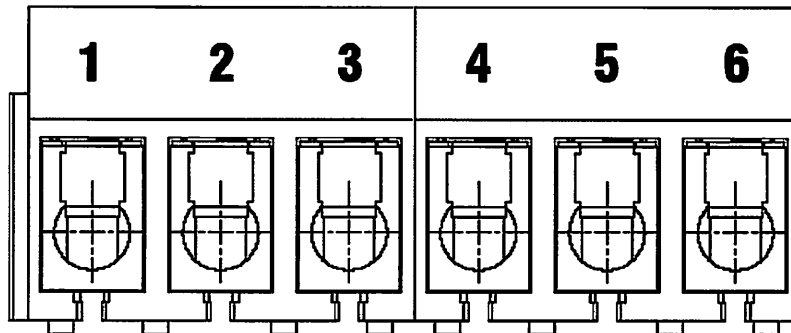

misapplication issue. This permanently damages the unit. If not corrected, it will happen again.

Tip: Visually confirm N-G bonding. Be aware that a voltmeter measuring N-G can be misleading. For example, N-G voltage could read 0V because neutral and ground are at the same potential by happenstance, not because they are bonded. Visually confirm bonding.

Tip: Experience indicates that regulation-challenged generators can cause Sustained Overvoltages, as well as ungrounded generators, and/or unusual load transfer systems.

Abnormal N-G Voltage Indicators

This SPD include N-G voltage indicators and a tattletale. If the SPD detects excessive N-G voltage, it will blink the Red Service LED and cycle the Audible Alarm while Phase LEDs are Green. If this occurs, DEENERGIZE THE SPD IMMEDIATELY and FIX THE N-G BONDING NOW. Otherwise, the SPD will fail.

Incorrectly bonded distribution systems are the number one killer of SPDs. If the XO or N-G bonding jumper is not installed, the electrical system has no reference to ground. It becomes an ungrounded system. Please see previous section regarding SPDs on ungrounded systems. Such systems are known to eventually produce abnormally high L-G voltages. SPDs will attempt to chase this system-level overvoltage abnormality until the SPD fails. This effect is accelerated on Wye systems where SPDs are designed for grounded systems. (SPDs for ungrounded systems generally have higher MCOV to allow for L-G voltage fluctuations.) Failures of this nature are not defects in the SPDs workmanship or material. This is an installation error, not a warrantable situation.

A differential voltage circuit monitors neutral to ground voltage. When N-G voltage becomes excessive, a shrink-wrap covered resistor will heat. After several minutes, the shrink wrap will shrink around the resistor. This diagnostic tool will not detect instantaneously excessive N-G voltages. If shrunk or tampered with, the warranty is voided. (When the SPD is deenergized, this resistor can be accessed by qualified personnel under the display plate cover. See Figure 11.

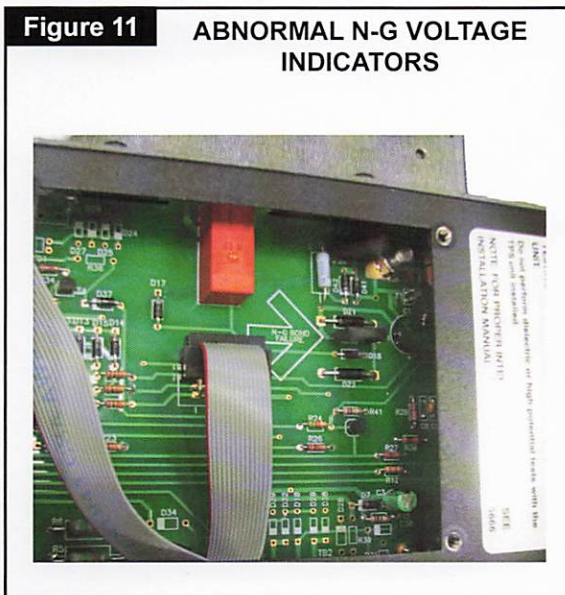

Module Replacement & Service

The module(s) is field replaceable. Deenergize SPD, confirm with appropriate measurement equipment and discharge internal capacitance to ground. Mark locations and carefully disconnect diagnostic cables, dry contact connections, phase conductors, unplug parallel connections on SPD. Depending on model, module may be bolted to backplane or the backplane may be part of the module assembly. Remove module/backplane. Reinstall in reverse order.

There are no user serviceable parts inside the module. We strongly recommend against disassembly.

Modules may be returned to the factory for factory service, qualification and return. Please contact the factory at (844) 697-6937 for assistance.

Display Replacement

The display is field replaceable. Deenergize SPD, confirm with appropriate measurement equipment and discharge internal capacitance to ground. Mark locations and carefully disconnect diagnostic cables, contacts, connecting conductors, etc. Unbolt display and replace. Reinstall in reverse.

Note that a sealing gasket between the display and the enclosure is a key component ensuring weather resistance. Replace the gasket whenever the display is removed.

SPD Series with two modules

One diagnostic display monitors both modules simultaneously via the parallel wire connections between the modules. These connectors plug in to each module, transferring information to internal logic on-board both modules.

If an inoperate condition were to occur, the diagnostic display will indicate a problem via red Service LED, audible alarm and dry contact change. Operation is identical to other ASP models.

Each BL module includes a red LED above the phase connection tabs, near the inter-module diagnostic wiring. An illuminated red LED indicates the damaged module.

Extra Information: Should one damaged module be removed, the SPD can still function correctly with one module. If the diagnostic display cable was connected to the removed module, reconnect the cable to the other module's quick release connector. The diagnostic display will function correctly. (SPDs with Type 4X or 4S enclosures have the diagnostic display mounted inside the enclosure on the right side module. If this module is removed, the diagnostic display may be moved to the other module. Remove the display's four screws, the display and appropriate internal ribbon cable. Remove blank cover from the remaining module and reassemble in reverse order.)

Figure 12 STANDARD & TYPE 4S MECHANICAL DRAWINGS

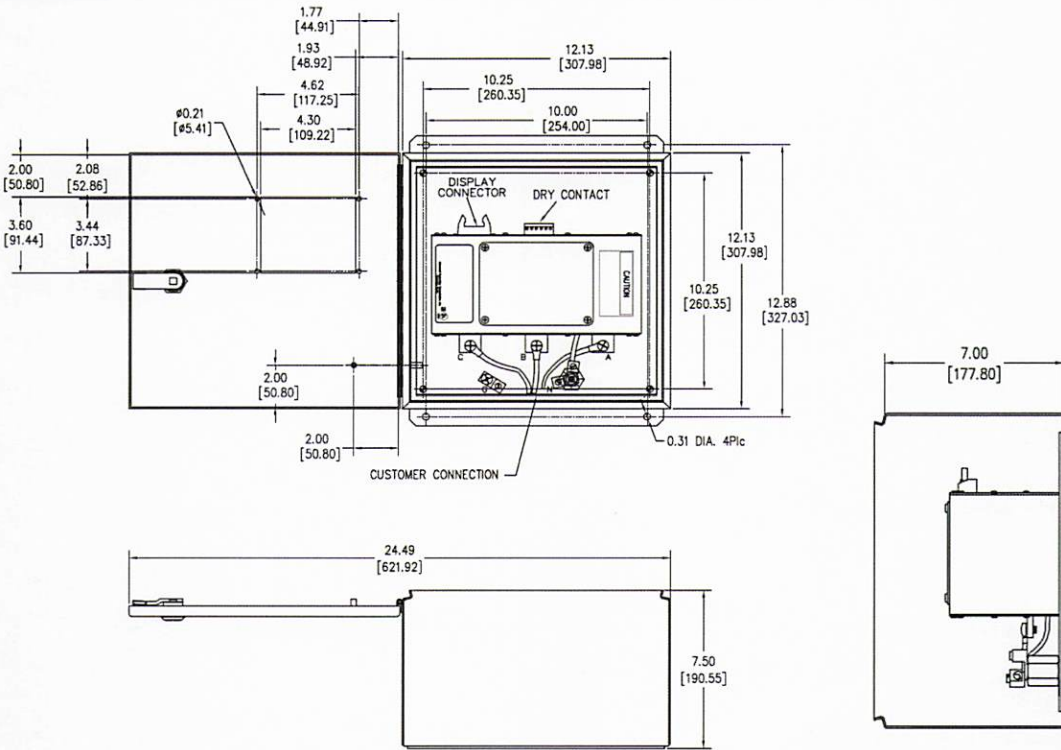

Figure 13 FLUSH MOUNT & SCREWCOVER PULLBOX MECHANICAL DRAWINGS

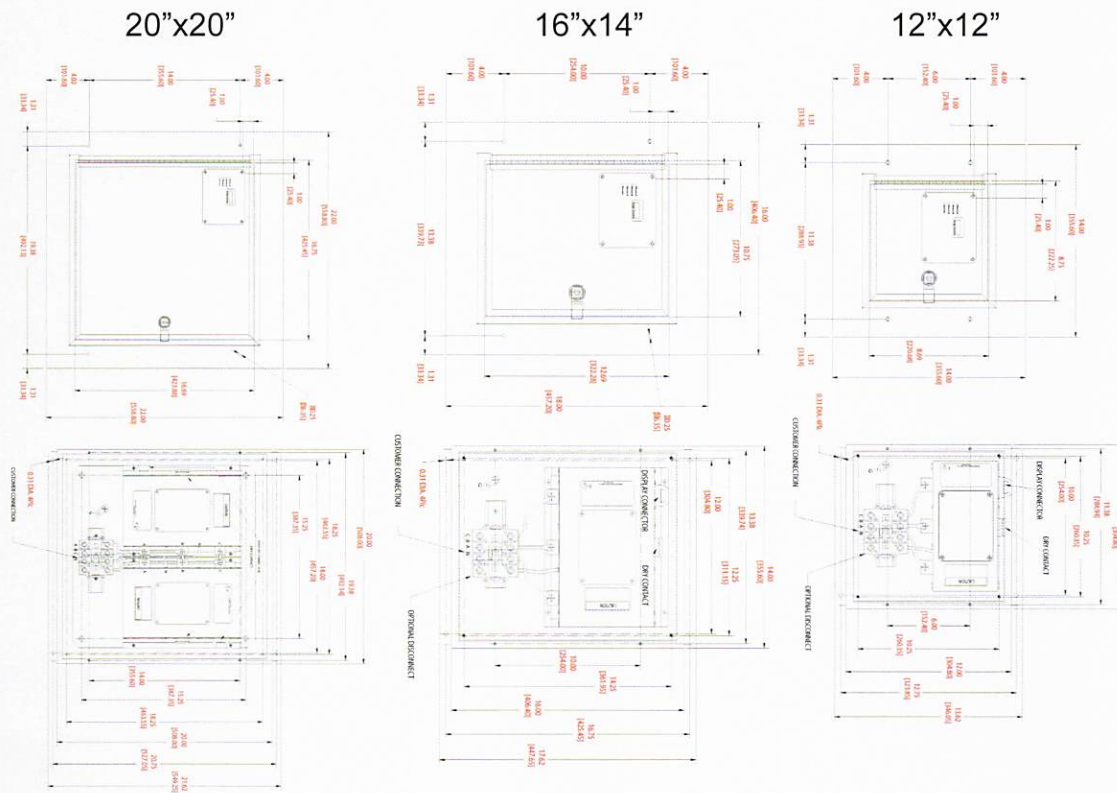
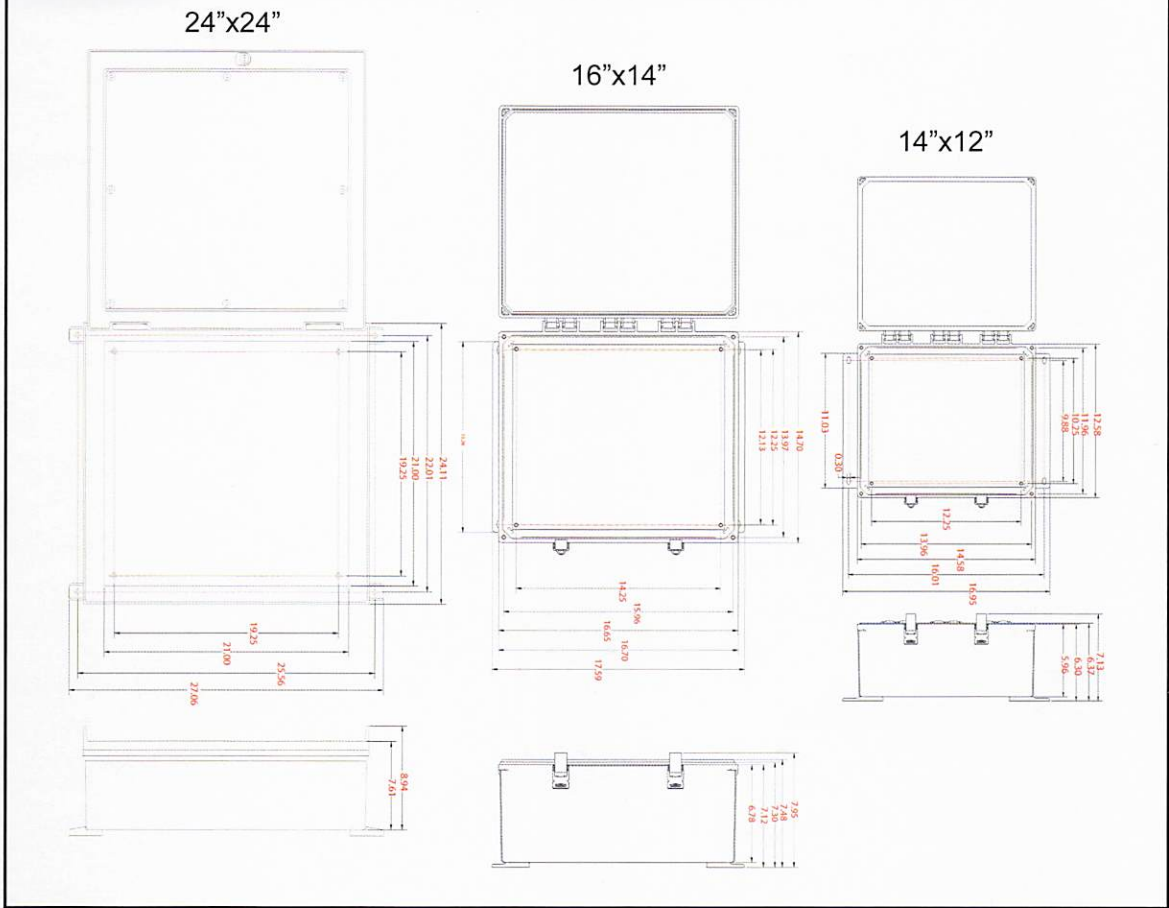

Figure 14 TYPE 4X NON-METALLIC MECHANICAL DRAWINGS



For larger drawings, please contact ASP at (844) 697-6937