

# CS Series

## Surge Protective Device (SPD)



# Installation, Operation & Maintenance Manual

Thank you for choosing an Atlantic South Power (ASP) Surge Protective Device (SPD). The CS is a high quality, high energy surge suppressor designed to protect sensitive equipment from damaging transient overvoltages. The CS is parallel connected such that circuit ampacity is unlimited. Proper installation is important to maximize performance. Please follow steps outlined herein. These instructions are not intended to replace national or local codes. Follow all applicable electrical codes to ensure compliance.

### WARNING – Risk of Electric Shock

- Only qualified licensed electricians should install or service SPDs
- SPDs should never be installed or serviced when energized or during electrical storms
- Use appropriate safety precautions including Personal Protection Equipment
- Failure to follow these instructions can result in death, serious injury, and/or equipment damage
- When used in outdoor applications, customer must seal the conduit nipple using watertight fittings (not included) to ensure a watertight connection
- Read this manual in its entirety prior to installing

### Industry Nomenclature Changes

In the late 2000's, there were significant nomenclature changes associated with a revision to UL 1449 and 2008 NEC® Article 285. Model 425 complies with the latest regulatory actions and is UL 1449 & CSA 22.2 No. 269, Listed as such (VZCA.E321351). There is an emphasis on installation location, identified as Types 1, 2 and 3.

**Type 1:** Installation on the line side or load side of the service disconnect overcurrent device. Type 1 SPDs may be used in Type 2 installations. Examples: surge arrestors, lightning arrestors, meter hubs, metering cabinets, ran out of breaker positions, etc.

**Type 2:** Downstream of service disconnect; probably will connect via breaker. Examples: switchboards, power panels, panelboards, equipment, motors, pumps, etc.

**Type 3:** Point of Use SPD, sometimes plug-connected SPD.

**Type 4:** Has different contexts in UL 1449 and CSA 22.2 No. 269. Call for assistance.

### NEC® Article 285 & UL 1449

SPD Types: Types 1, 2, & 3

Based on Location within electrical distribution system

(also coincides with ANSI/IEEE C62.41.2 - 2002 Categories C, B & A)

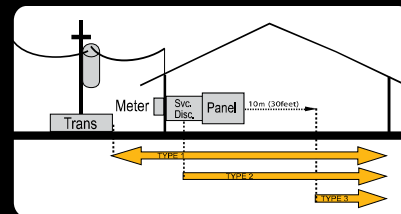

## Atlantic South Power Critical Systems

PO Box 1387 · Highlands, North Carolina 28741  
(844) 697-6937 · [www.atlanticsouthpower.com](http://www.atlanticsouthpower.com)

UL is a registered trademark of Underwriters Laboratories, NEC® and National Electrical Code are registered trademarks of National Fire Protection Association, C62.41.1-2002, C62.41.2-2002, C62.45-2002, C62.72-2007 are registered trademarks of IEEE.

# INSTALLATION

Pre-Plan your installation. You need to accomplish the following:

- Meet all National and Local codes (NEC® Article 285 and UL 1449 address SPDs).
  - Confirm System voltage to SPD voltage (120V SPD will fail instantly on 240V, 277V, etc.).
  - Mount SPD as close to panel or equipment as possible to keep leads short (long leads hurt performance).
  - Ensure leads are as short and straight as possible, including neutral and ground. If using a breaker, use a breaker position that is close to the SPD and the panel's neutral and ground.
  - If using a breaker, recommended breaker size is 30A due to 10 AWG conductor.
  - Make sure system is grounded per NEC® and clear of faults before energizing SPD (inadvertent system problem may fail SPD).
  - Never Hi-Pot test Any SPD (will prematurely fail SPD).
  - Do not install the CS through the bottom of a NEMA 3R panel. Dripping water will prematurely fail the SPD (a sealed pipe nipple installed in the SPD may be a solution).
1. Use voltmeter to check voltages and ensure correct SPD. See Data Sheet for specs and wire-outs.
  2. Determine Mounting location – weather resistant equipment may be required.
  3. If SPD has optional Dry Contact Flush Mount Kit, or Remote Indicator, pre-plan their installation. See Figure 3. (If flush mounting, be careful to not drop SPD into wall).
  4. Remove power from panel/source. Confirm panel/source is deenergized.
  5. Identify breaker location and SPD location. Position SPD such that LEDs are best visible.
  6. Mount SPD – weather resistant applications require additional sealing, etc. (not included)
    - Remove an appropriately sized knockout from panel.
    - Connect conductors as appropriate – short and straight as possible (Hi-Legs are Phase B).
  7. Label or mark conductors as appropriate (neutral: white, ground: green, energized: black, hi-leg: orange).
  8. Make sure system is bonded per NEC® and is clear of hazards or faults before energizing (N-G bonding not per NEC® will fail SPDs: #1 cause of SPD failures).
  9. Energize and confirm proper operation of green LED indicators and/or options.

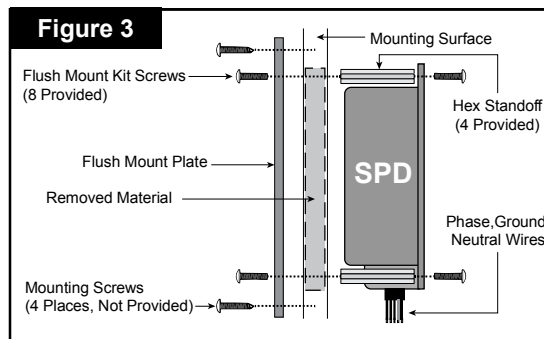
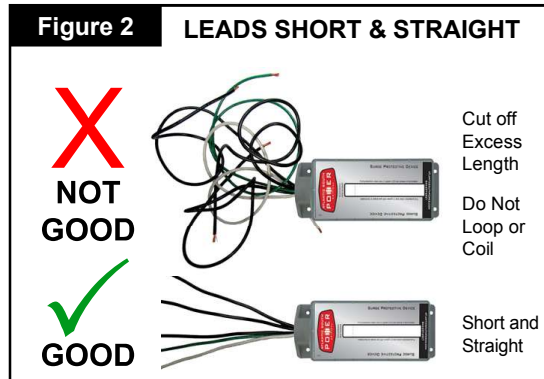
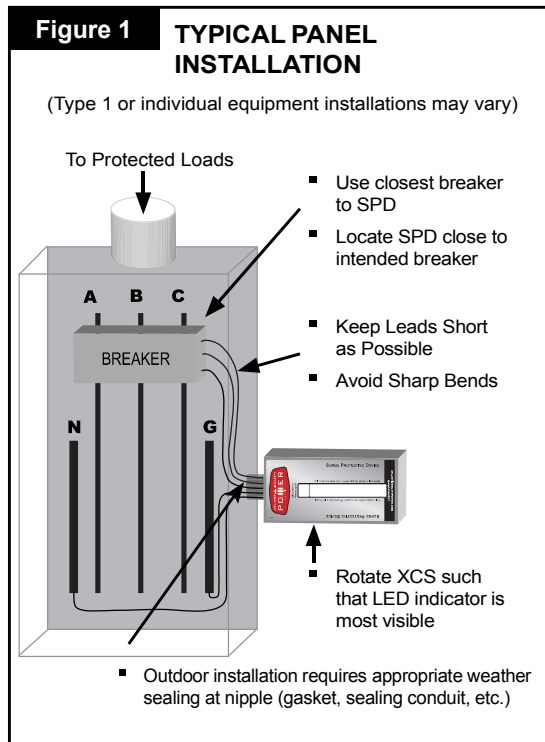

**WARNING**

- Confirm XO N-G Bonding at Upstream Transformer
- Do Not Hi-Pot Test
- Resulting Damage is not Covered Under Warranty

**WARNING**

VERIFY THAT ALL POWER CIRCUITS ARE DEENERGIZED BEFORE MAKING CONNECTIONS

All electrical connections should be performed by a qualified (licensed) electrician or technician. All wiring must comply with the National Electrical Code (NEC®) and applicable local codes.

The CS is a Type 1 SPD. The CS is suitable for use almost anywhere (not as a plug-in SPD). Type 1 SPDs are evaluated more rigorously by UL 1449 for 2008 NEC® Article 285 compliance. Type 1 SPDs and their connecting leads have been evaluated for line side applications without need for supplemental overcurrent protection. Type 1 SPDs include internal overcurrent protection. As a generalization, there are practical maintenance reasons for installing on the load side of the main overcurrent device (i.e. Type 2 installation). When connected on load side of main disconnect, we recommend connecting via a 30A circuit breaker due to 10 AWG conductors. The circuit breaker serves as a disconnect switch and provides NEC® imposed short circuit protection to the conductors in Type 2 or 4 applications. (cUL models are Type 2 due to different cUL criteria.)

**Simplified Explanation of Operation:** SPDs sense overvoltage and create a momentary short circuit to redirect harmful surge energy to earth ground. They reset automatically and wait for the next surge. This is similar to the pressure relief valve on a water heater: pressure goes up, valve opens to relieve pressure and then resets. In an electrical system, an SPD senses overvoltage, shorts temporarily sending energy to ground and then resets. SPDs are capable of repeating this function thousands of times.

**Parts List**

- 1 - CS suppressor including 3' (~1m) conductors
- 1 - Installation Sheet (this document)
- 1 - Data Sheet (attached)

**If the Flush Mount Kit was ordered, additional parts include:**

- 1 - Flush Mount Plate
- 4 - Mounting Screws
- \*See Figure 3 For Installation

Most CS have demonstrated 200kA or 100kA Short Circuit Current Ratings (SCCR) including leads. See UL Label markings on SPD or see Data Sheet for specs.) Supplemental overcurrent protection is not required to protect this SPD. However, NEC® convention requires that connecting conductors have overcurrent protection in Type 2 or 4 applications. Follow applicable codes.

This device features internal overcurrent and overtemperature protection that will disconnect effected surge suppression components at the end of their useful life, but will maintain power to the load – now unprotected. If this situation is undesirable for the application, follow these instructions for replacing the device. XCS is ultrasonically welded closed and contains no user serviceable parts.

| Specifications                                      |   |
|---|---|
| Temperature Operating                               | -40°C (-40°F) to 85°C (+185°F)                        |
| Temperature Storage                                 | -55°C (-67°F) to 65°C (+149°F)                        |
| Wire Size & Installation Torque                     | 10 AWG; 18 inch-pounds                                |
| Appropriate Circuit Breaker based on conductor size | 30A (SPD includes internal OCP)                       |
| NEMA 250 Enclosure Rating                           | Type 4X with appropriate sealing and sealing conduits |

**Voltage Rating & Application**

Before installing SPD, verify by nameplate voltage or model number that it has the same voltage rating as the power distribution system. See attached Data Sheet or call ASP Tech Support at (844) 697-6937 as appropriate. The SPD’s specifier or user should be familiar with the configuration and arrangement of the power distribution system. The system is defined by how the secondary windings of the transformer supplying the service entrance main or load are configured. This includes whether or not the transformer windings are referenced to earth via a grounding conductor. The system configuration is not based on how any specific load or equipment is connected to a particular power distribution system. SPDs should be installed per the distribution system, not per a load or motor’s wiring connection.

For example, suppose a 480V three phase motor appears to be connected as a 480V Delta. In actuality, the serving distribution system might be a 480Y/277V grounded Wye, with or without a neutral pulled to the motor or MCC. The system is still a 480Y/277V Wye, even though the load is connected as a Delta. A grounded Wye has a defined reference to ground (i.e., neutral is bonded to ground). In contrast, some Delta systems are ungrounded, which have no reference to ground.

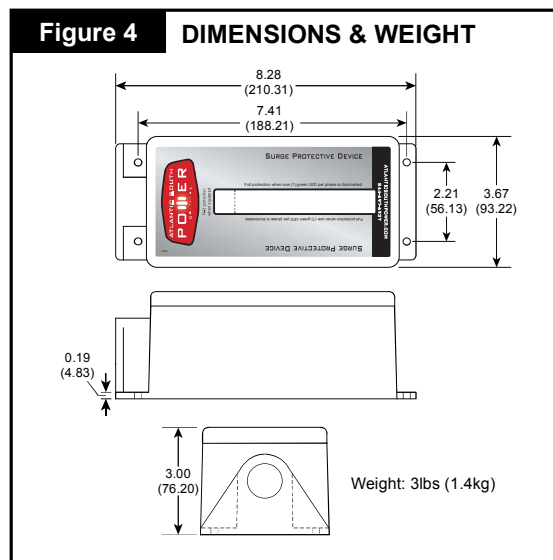

## SPDs on Ungrounded Systems

Caution – Ungrounded systems are inherently unstable and can produce excessively high line-to-ground voltages during certain fault conditions. During these fault conditions, any electrical equipment including an SPD, may be subjected to voltages which exceed their designed ratings. This information is being provided to the user so that an informed decision can be made before installing any electrical equipment on an ungrounded power system.

### Connecting Optional Form C Dry Contact & Audible Alarm

Three (3) 3' (~1m) 18 AWG wires are included through the nipple with this option. (These are smaller than the 10 AWG SPD conductors.) Gray is Common, Blue is Normally Open and Red is Normally Closed. (We generally recommend the Normally Closed configuration because it detects disconnected or failed wiring whereas Normally Open does not.) The contact is rated 250V, 5A. Higher energy applications require supplemental relaying. This option monitors suppression element condition and is not intended for use as phase loss or phase detection monitoring. If the Dry Contacts are not utilized, insulate lead ends, coil and secure. Audible Alarm will still function correctly.

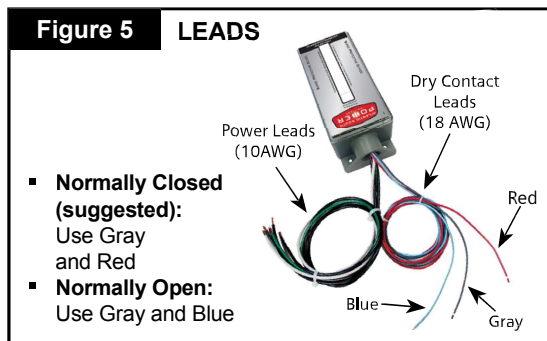

### Remote Indication Option

This is a supplemental diagnostic LED that can be mounted in a conspicuous location if the SPD is installed such that on-board LEDs are not readily visible. A green LED bezel assembly includes two pre-attached wires and two butt-splice connectors. The SPD includes two yellow 18 AWG wires, pre-wired through the SPD's nipple mounting connection. Pre-plan the installation per normal installation Instructions. Mount the LED assembly in an appropriate conspicuous location. Connect the LED wires to the yellow SPD wires with the provided butt-splice connectors. These are not polarity



sensitive. Test by energizing and deenergizing SPD. Operation is straightforward: green LED On = SPD is OK. If the LED is out, the SPD has failed, power is not present, or one of more phases are not energized.

## NORMAL OPERATION

### Green LED Indicators

Each phase has an LED indicator, which illuminates when the SPD is energized and operating correctly. SPDs equipped with Neutral-Ground protection include a N-G LED at one end of the translucent white label window. SPDs without N-G protection such as those for Delta power systems do not include this feature. Every suppression element is monitored and connected by logic to the LED. Should any suppression element fail, the Green LED will extinguish.

### Form C Dry Contact and Audible Alarm Option

Similar to the green LEDs above, the Dry Contact will change state and the Audible Alarm will sound upon suppression element failure. The Audible Alarm may be silenced by removing power to the SPD.

## MAINTENANCE

SPDs require minimal maintenance. We recommend periodic inspection of diagnostic indicators to ensure proper operation. We also recommend keeping the SPD clean as appropriate.

### Troubleshooting & Service

Please contact us for any service related issues. We want to take care of any problems.

Quality SPDs withstand severe duty and attempt to protect their load until failure. There are electrical anomalies that SPDs cannot protect against. These are generally Sustained Overvoltages also known as Temporary Overvoltages (TOVs). In this context, Sustained Overvoltages may be only a few cycles. Failed SPDs tend to be symptoms, not root causes. We suggest treating a failed SPD as a 'canary in the coal mine' as there may be larger issues at play. As a generalization, the single largest 'killer' of SPDs is reference to ground issues. If the SPD shows problems on startup, there is reasonable chance of bonding/grounding/misapplication issue. This permanently damages the unit. If not corrected, it will happen again.

There are no user serviceable parts inside. We strongly recommend against disassembly.

Units may be returned to the factory for factory service, qualification and return. Please contact factory at (844) 697-6937 for assistance.